

INCREMENTA LA PRODUTTIVITÀ / INCREASE YOUR PRODUCTIVITY

**POSIZIONAMENTO  
ed ANCORAGGIO  
ISTANTANEO**

**IMMEDIATE  
POSITIONING  
& CLAMPING**



SCOPRI DI PIÙ - FIND OUT MORE

PRECISO, RAPIDO & SICURO  
ACCURATE, QUICK & SAFE

DOUBLE  
EFFECT

95%  
SAVING COSTS

REDUCE  
SET UP TIME

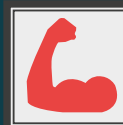

Montaggio incassato  
Built-in mounting



**Art.664**

Montaggio con flangia  
Mounting with flange



**Art.665T**

Zero-Point doppio  
Double Zero-Point

Lo Zero Point è un sistema di posizionamento ed ancoraggio istantaneo, rappresenta la soluzione ideale per la movimentazione ed il serraggio preciso, rapido e sicuro delle attrezzature sul pallet delle macchine utensili.

Lo Zero Point è un sistema "NORMALMENTE CHIUSO", utilizza molle che permettono il bloccaggio del tirante mediante le sfere poste all'interno mentre l'aria compressa, filtrata e lubrificata, serve per lo sbloccaggio.

The Zero Point is an immediate positioning and clamping system, that represents the ideal solution for the positioning and the precise, fast and firm clamping of the equipments on the machine tools.

The Zero Point is a system "NORMALLY CLOSED", that uses die springs which allows the clamping of the pull-stud through the spheres located inside, while the filtered and lubricated compressed air enables the release.

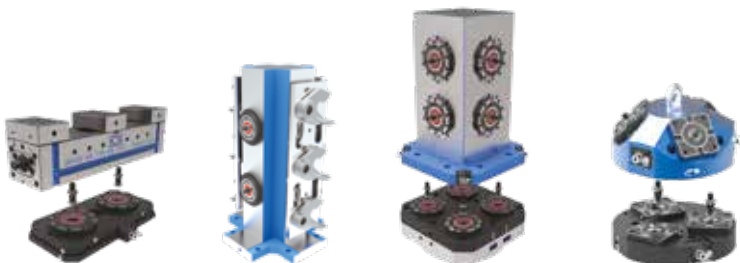



## PNEUMATICO MULTIPLO MULTIPLE PNEUMATIC

Repeatability within 0,005 mm

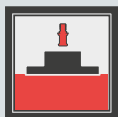

Art.664

CON FLANGIA - WITH FLANGE

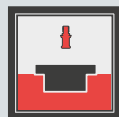

Art.665

INCASSATO - BUILT-IN

Forza di serraggio 3 + 42 kN / Forza di arresto oltre a 60 kN / Sbloccaggio ad aria 6 + 14 bar / Cono di posizionamento con pinza elastica  
Doppio centraggio per tirante per massima rigidità / Pulizia ad aria / Chiavetta antirotazione / Doppio effetto  
Clamping force 3 + 42 kN / Holding force more than 60 kN / Pneumatic release 6 + 14 bar Positioning shank with elastic collet  
Double pull-stud centering for Max rigidity / Air cleaning / antirotation keyway / Double effect

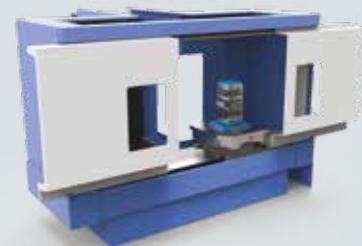

## PNEUMATICO SINGOLO SINGLE PNEUMATIC

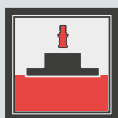

Art.664S

CON FLANGIA - WITH FLANGE



Art.665S

INCASSATO - BUILT-IN

Forza di serraggio 3 + 42 kN / Forza di arresto oltre a 60 kN / Sbloccaggio ad aria 6 + 14 bar / Cono di posizionamento con compensazione assiale  
Doppio centraggio per tirante per massima rigidità / Pulizia ad aria / 4 Chiavette antirotazione / Doppio effetto  
Clamping force 3 + 42 kN / Holding force more than 60 kN / Pneumatic release 6 + 14 bar Positioning shank with axial compensation / Double pull-stud centering for Max rigidity / Air cleaning / 4 antirotation keyways / Double effect



example

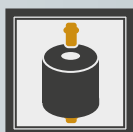
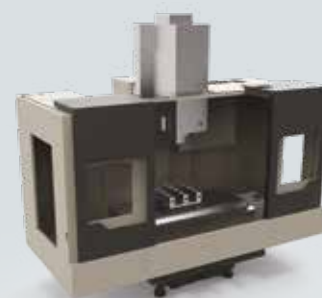

## ZERO POINT DOPPIO - DOUBLE ZERO POINT

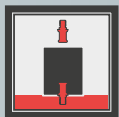

Art. 665T

DOPPIO - DOUBLE

Forza di serraggio 3 + 42 kN / Forza di arresto oltre a 60 kN / Sbloccaggio ad aria 6 + 14 bar / Cono di posizionamento con compensazione assiale / Doppio centraggio per tirante per massima rigidità / Pulizia ad aria / 4 Chiavette antirotazione / Doppio effetto

Clamping force 3 + 42 kN / Holding force more than 60 kN / Pneumatic release 6 + 14 bar / Positioning shank with axial compensation / Double pull-stud centering for Max rigidity / Air cleaning / 4 antirotation keyways / Double effect

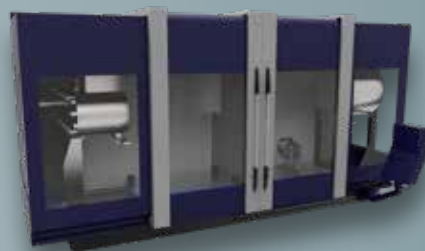

### ABBATTIMENTO TEMPI DI ALLESTIMENTO MACCHINA - PRODUCTION OPTIMIZATION

Il sistema Zero Point vi permette di rimuovere in pochi secondi le attrezzature sulla macchina, in modo da poter effettuare l'attrezzaggio a banco e sostituirlo a lavoro ultimato, risparmiando fino al 95% sui tempi di allestimento. Ipoteticamente dovendo impiegare 2 ore al giorno a € 40,00 all'ora per attrezzare ogni macchina, attrezzare 5 macchine a CNC vi costa all'incirca € 100.000 in profitti persi ogni anno. Il sistema Zero Point vi permette di salvare centinaia di ore di "tempi morti" e avere più profitti.

The table illustrates how much it costs on just 1 machine to set up jobs on the machine. Zero Point allows you to set up jobs off the machine and position the new job/vise in few seconds on the machine when the last job finishes, saving around 95% set up time. 5 CNC machines being set 2 hours a day @ € 40,00 an hour is costing you at least € 100.000 in lost profits every year. Zero Point will allow you to save hundreds of hours in down time and make thousands more in profits.

Costo orario della macchina Machine cost per hour	Tempo giornaliero per attrezzaggio Time per day to set-up machine	Costo annuale dei "tempi morti" Cost per year of down time*	Potenziale profitto extra con Zero Point Zero Point potential extra profit
€ 25,00	2 ORE / HOURS	- € 12.500 persi / lost	- € 11.875 risparmio / savings
€ 40,00	2 ORE / HOURS	- € 20.000 persi / lost	- € 19.000 risparmio / savings
€ 60,00	2 ORE / HOURS	- € 30.000 persi / lost	- € 28.500 risparmio / savings
€ 75,00	2 ORE / HOURS	- € 37.500 persi / lost	- € 35.625 risparmio / savings



**IL SISTEMA ZERO POINT IDEALE PER IL TUO CENTRO DI LAVORO  
THE IDEAL ZERO POINT SYSTEM FOR YOUR MACHINE**

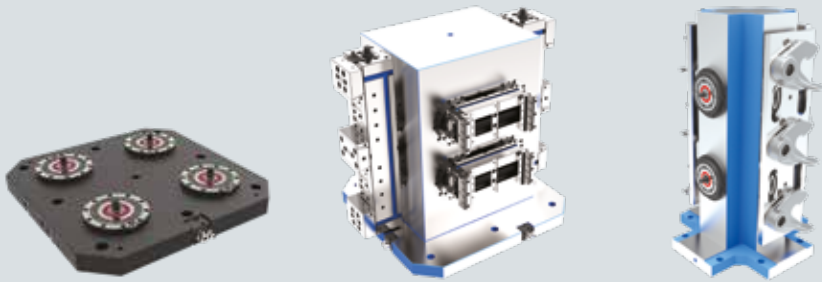

**Horizontal Machining Centres**



**Centri Orizzontali  
Horizontal Centres**



**Vertical Machining Centres**

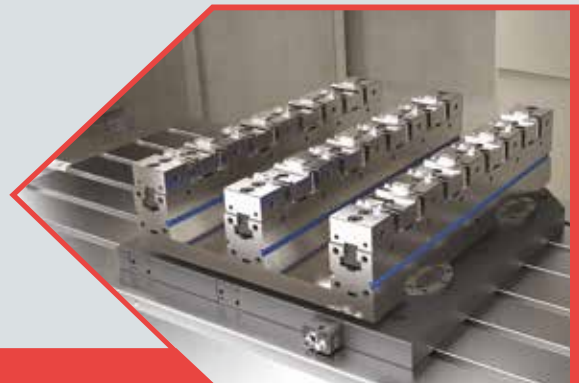

**Centri Verticali  
Vertical Centres**



**5 Axis Machining Centres**



**Centri A 5 Assi  
5 Axis Centres**

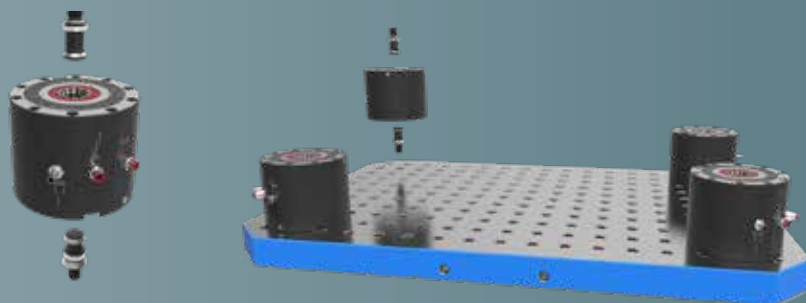

**Milling Machines**



**Fresatrici  
Milling machines**

**INCREMENTA LA FORZA DI SERRAGGIO - INCREASE CLAMPING POWER**

Pressione apertura Opening pressure	Art.665/S Type 1		Art.665 Type 2		Art.665S Type 2		Art.665/S Type 3	
	kN	kN *	kN	kN	kN *	kN	kN *	
Entrata - Input								
4 Bar	2,5	7,5	6	5	12,5	7,5	25	
5 Bar	3,7	10	7,5	7,5	20	10	31	
6 Bar	5	12,5	9,5	10	26	13,5	37,5	
7 Bar	-	-	11	-	-	15	42	
10 Bar	-	-	5	-	-	-	-	
12 Bar	-	-	12,5	12,5	-	-	-	
14 Bar	-	-	15	-	-	18	-	

\* Utilizzando la funzione DOPPIO EFFETTO - Using the DOUBLE EFFECT function



**1kN**

**MOLLA SINGOLA**  
SINGLE SPRING

**10kN**

**TOTALE MOLLE**  
ALL SPRINGS

**25kN**

**DOPPIO EFFETTO**  
DOUBLE EFFECT

La funzione DOPPIO EFFETTO permette di ottenere parametri di serraggio notevolmente superiori rispetto al normale funzionamento. Quando è azionata l'aria compressa aggiunge una forza pneumatica in supporto al normale sistema di serraggio tramite molle.

The DOUBLE EFFECT function allows to get clamping results much higher than the normal. When the double effect is operated the air adds a pneumatic clamping power which supports and increases the normal clamping through springs.



**5**

**PER CENTRI A CINQUE ASSI  
FOR FIVE AXIS MACHINING CENTERS**

PIASTRE TONDE INTERFACCIAE CON ZERO POINT / ZERO POINT INTERFACED ROUND HEAD PLATES

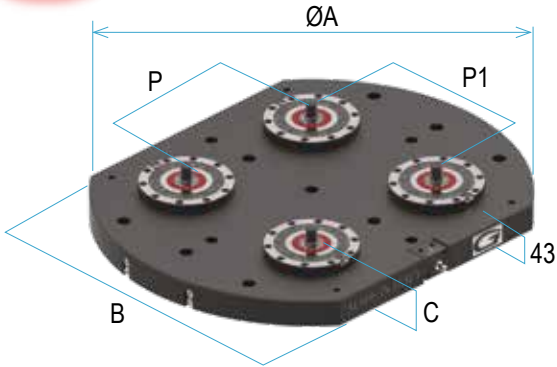

**DISPONIBILE ANCHE  
ALSO AVAILABLE**



**Art. 72CP**

Carter per piastre tonde con Zero Point pneumatici  
Cover for pneumatic Zero Point round plate

**Art. 72P**

Piastra tonda con Zero Point montaggio con flangia Art.664  
Round plate with Zero Point flange mounting

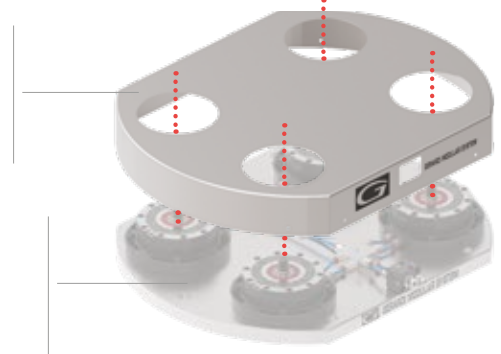

**Art. 82P**

Piastra tonda con Zero Point Art.665 montaggio incassato  
Round plate with Zero Point Art.665 built-in mounting

Dimensioni Dimension	Hermule C600U	DMG DMU 50 Evo	Mazak Variax 500	Hermule C40U	DMG DMU 50	Haas UMC 750SS	Mazak Variax 630	DMG DMU 70 Evo	DMG DMC 635V	DMG DMC 1035V	DMG DMU 80P
<b>ØA</b>	280	500	500	420	630	500	630	700	790	1000	900
<b>B</b>	-	380	400	-	500	400	500	500	560	560	630
<b>C</b>	58	58	58	58	58	58	58	58	58	58	58
<b>P</b>	150	200 / 250	200 / 250	200	200 / 250 / 300	200 / 250	200 / 250 / 300	200 / 300 / 400	200 / 250	200 / 250 / 350	200 / 250 / 300
<b>P1</b>	-	200	200 / 250	200	200 / 250 / 300	200 / 250	200 / 250 / 300	200 / 250 / 300	200 / 300 / 400	200 / 300 / 400	200 / 300 / 400
N° Zero Point	1	4	4	4	4	4	4	4	6	8	6
kg	25 15	67 29	69 31	56 26	103 43	69 31	103 43	116 48	149 63	197 83	188 87



**Attrezzaggio Rapido**  
Reduce Down Times

Abbattimento dei tempi di allestimento macchina del 95%

Minimum machine set up times. 95% Reduction.



**Distanziali**  
Risers

Grazie ai rialzi per Zero Point è possibile lavorare parti del particolare difficili da raggiungere

By the Risers for Zero Point it's possible machining areas usually hard to reach.



**Produzione ottimizzata**  
Production optimization

Incremento della produzione e riduzione degli scarti

Increase productivity and reduce scraps



**Zero Point Doppi**  
Double Zero Point

Adattabile ad ogni interasse tramite piastra a reticolo

Any pitch will do through grid type plate